

PL OD PRODUCENTA

Dziękujemy za wybór produkowanego przez naszą firmę zaczepu kulowego. Jego niezawodność została potwierdzona licznymi testami oraz opiniami zadowolonych klientów. Jednakże niezawodność zaczepów kulowych jest zależna również od prawidłowego montażu oraz prawidłowej eksploatacji. Z tego powodu prosimy Państwa o staranne przeczytanie niniejszej instrukcji montażu oraz przestrzeganie właściwych wskazówek.

Zaczep należy zamontować w miejscach do tego celu przeznaczonych przez producenta samochodu.

GB FROM MANUFACTURER

Thank you for buying our product. Their reliability has been confirmed in many tests. Reliability of towing hitch depends also on correct assembly and right operation. For this reasons we kindly ask to read carefully this instruction and apply to hints.

The towing hitch should be install in points described by a car producer.

D VON DEM HERSTELLER

Die Zuverlässigkeit der Anhängerkupplung ist jedoch auch von der ordnungsgemäßen Montage und der richtigen Nutzung abhängig. Daher werden Sie gebeten, sorgfältig die folgende Montageanleitung zu lesen und sich an die entsprechenden Anweisungen zu beachten.

Die Anhängerkupplung muss an den vom Fahrzeughersteller vorgeschriebenen Befestigungsstellen montiert werden.

F DE LA PART DU FABRICANT

Merci d'avoir choisi le dispositif d'attelage à boule produit par notre société. Son fiabilité a été confirmée dans de nombreux tests et par les opinions des clients satisfaits.

Toutefois, la fiabilité des dispositifs d'attelage à boule dépend aussi d'installation et d'exploitation correcte. Pour cette raison, nous vous demandons de lire attentivement cette instruction de montage et de respecter les conseils.

Le dispositif d'attelage à boule doit être monté dans des emplacements prévus à ce but par le fabricant de voiture.



PPUH AUTO-HAK S.J.

Henryk & Zbigniew Nejman
76-200 SŁUPSK ul. Słoneczna 16K
tel/fax (059) 8-414-414; 8-414-413
E-mail: office@autohak.com.pl
www.autohak.com.pl



LAND ROVER FREELANDER 2

D 11,0 kN

Typ: LN02

kg 2300



2007 →



150



e20*94/20*0521*00



1,5h

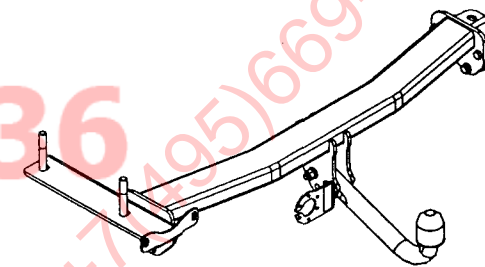

M6 - 11 Nm
M10 - 50 Nm
M14 - 138 Nm

M8 - 25 Nm
M12 - 87 Nm
M16 - 210 Nm



0 km



1000 km

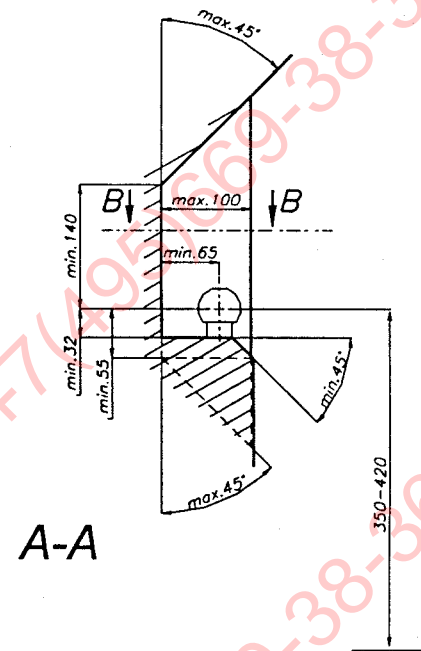

PL

Należy zagwarantować przestrzeń swobodną według załącznika VII, ilustracja 30 wytycznej 94/20/WE przy dopuszczalnym ciężarze całkowitym pojazdu.

GB

The clearance specified in appendix VII, diagram 30 of guideline 94/20/EC must be guaranteed at laden weight of the vehicle.

D

Der Freiraum nach Anhang VII, Abbildung 30 der Richtlinie 94/20/EG ist zu gewährleisten bei zulässigem Gesamtgewicht des Fahrzeuges.

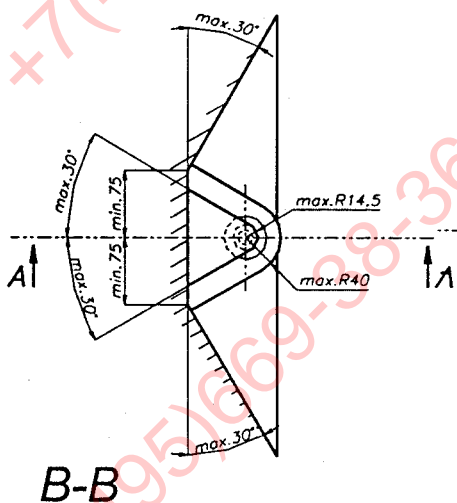

F

L'espace libre doit être garanti conformément à l'annexe VII, illustration 30 de la directive 94/20/CE pour poids total en charge autorisé du véhicule.

PL

Zaczepek kulowy jest skonstruowany zgodnie z zasadami bezpieczeństwa ruchu drogowego. Zaczepek kulowy jest elementem wpływającym na bezpieczeństwo jazdy i może zostać zainstalowany wyłącznie przez personel wyspecjalizowany. Niedopuszczalne jest dokonywanie jakichkolwiek zmian w konstrukcji zaczepeku. Powoduje to wygaśnięcie dopuszczenia do stosowania. W przypadku obecności masy izolacyjnej lub osłony podwozia w miejscu przylegania zaczepeku, należy ją usunąć. Nieosłonięte miejsca karoserii oraz wywiercone otwory należy pomalować farbą antykorozyjną. Informacjami wiążącymi odnośnie wartości obciążeń są dane podawane przez producenta samochodu, względnie wartości maksymalnej masy przyczepy oraz maksymalnego nacisku na kulę, przy czym wartości parametrów zaczepeku kulowego nie mogą być przekroczone.

Wzór do obliczania wartości siły D:

$$\frac{\text{Maks. masa przyczepy [kg]} \times \text{Maks. masa samochodu [kg]} \times 9,81}{\text{Maks. masa przyczepy [kg]} + \text{Maks. masa samochodu [kg]} \times 1000} = D \text{ [kN]}$$

GB

This towing hitch is designed according to rules of safety traffic regulations. The towing hitch is a safety component and can be install only by qualified personnel. Any alteration or conversion of the towing hitch is prohibited and would lead to cancellation of design certification. Remove insulating compound and underseal from vehicle (if present) in the area of the matting surfaces of the towing hitch.

The vehicle manufacturer's specifications regarding trailer load and max. vertical cup load are decisive for driving whereat values for the towing hitch cannot be exceeded.

D-value formula:

$$\frac{\text{Max trailer weight [kg]} \times \text{Max vehicle weight [kg]} \times 9,81}{\text{Max trailer weight [kg]} + \text{Max vehicle weight [kg]} \times 1000} = D \text{ [kN]}$$

D

Die Anhängerkupplung erfüllt die Vorschriften der Verkehrssicherheit. Sie beeinflusst die Fahrsicherheit und daher ist ausschließlich nur vom Fachpersonal zu montieren. Es dürfen keinesfalls Konstruktionsänderungen vorgenommen werden. Sonst erlischt die Verwendungszulassung.

Falls es eine Isolationsschicht oder Fahrzeugunterbodenschutz gibt, wo die Anhängerkupplung befestigt wird, so sind diese zu entfernen. Andere Karosseriestellen und gebohrte Löcher sind mit der Antikorrosionsfarbe anzustreichen.

Für die Belastungswerte gelten die vom Fahrzeughersteller angegebenen Daten bzw. max. Masse der Anhänger und max. Stützlast. Dabei dürfen die Höchstkennwerte der Anhängerkupplung nicht überschritten werden.

D-Wert Formel:

$$\frac{\text{max. Masse Anhänger [kg]} \times \text{Max. Fahrzeugesamtgewicht [kg]} \times 9,81}{\text{max. Masse Anhänger [kg]} + \text{Max. Fahrzeugesamtgewicht [kg]} \times 1000} = D \text{ [kN]}$$

F

Le dispositif d'attelage à boule est conçu en conformité avec les principes de sécurité de la circulation route. Le dispositif d'attelage à boule est un facteur qui influence la sécurité routière et peut être installé uniquement par du personnel qualifié.









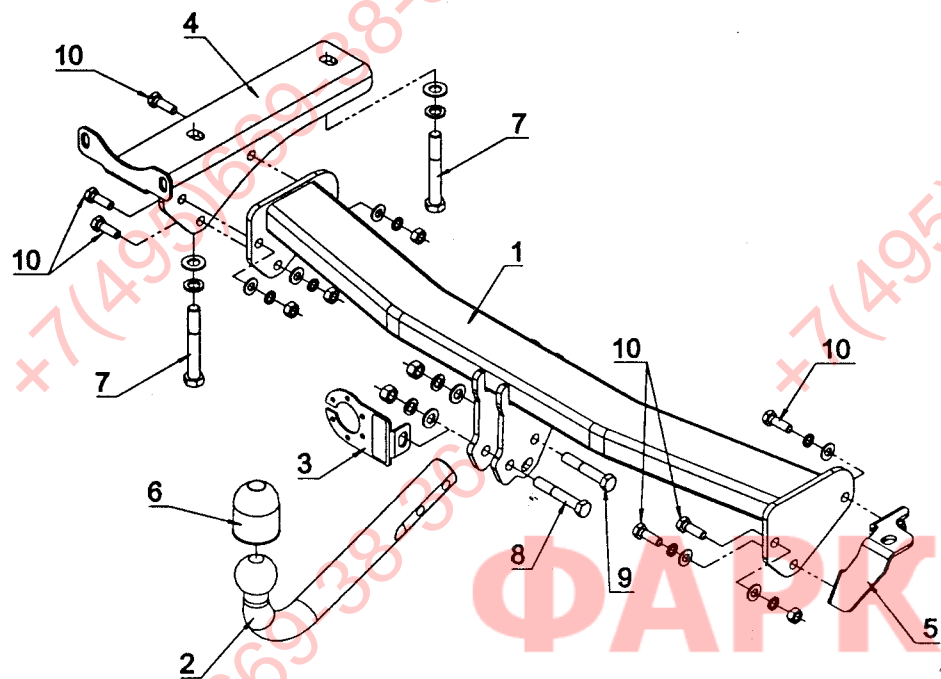

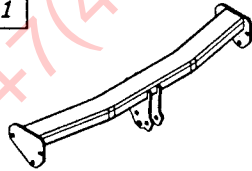





Toute modification sur la construction du dispositif d'attelage est interdit. Cela entraîne l'annulation de l'autorisation de mise en circulation. S'il y en a une, enlever le mastic isolant ou la couche de protection au châssis, à proximité de la surface d'appui du crochet. Appliquer une couche de protection antirouille sur les parties nues de la carrosserie et sur les trous.

Les informations contraignantes quant aux valeurs des charges sont celles, fournies par le constructeur de véhicule, ou le poids maximal de remorque et pression max autorisée sur la boule d'attelage. Les valeurs des paramètres du dispositif ne peuvent pas être dépassées.

La formule pour calculer la puissance D:

$$\frac{\text{poids maximum de remorque [kg]} \times \text{poids maximum de véhicule [kg]} \times 9,81}{\text{poids maximum de remorque [kg]} + \text{poids maximum de véhicule [kg]} \times 1000} = D \text{ [kN]}$$



1		x1		7 M14x100	x2
2		x1		8 M12x75	x1
3		x1		9 M12x70	x1
4		x1		10 M10x30	x6
5		x1		11 \varnothing 15	x2
6		x1		12 \varnothing 13	x2
				13 \varnothing 10.5	x6
				14 \varnothing 14.2	x2
				15 \varnothing 12.2	x2
				16 \varnothing 10.2	x6
				17 M12	x2
				18 M10	x4

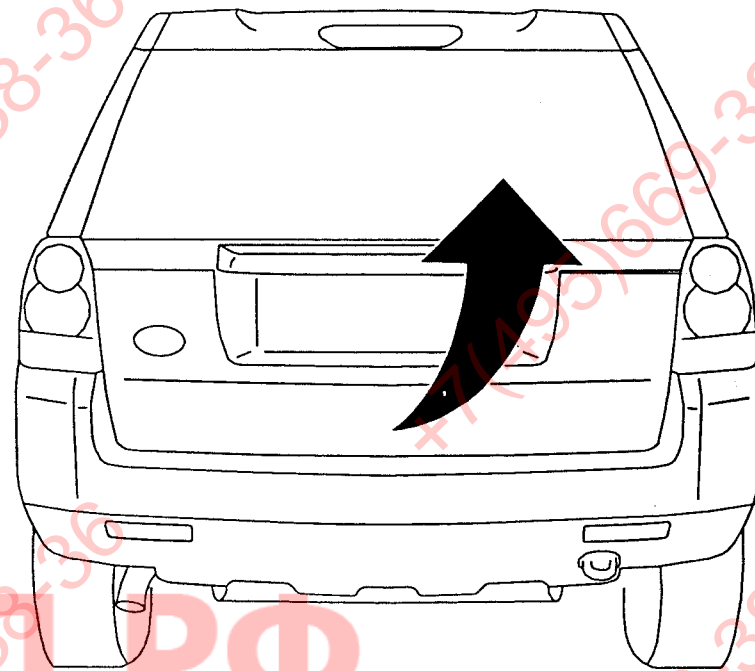

01

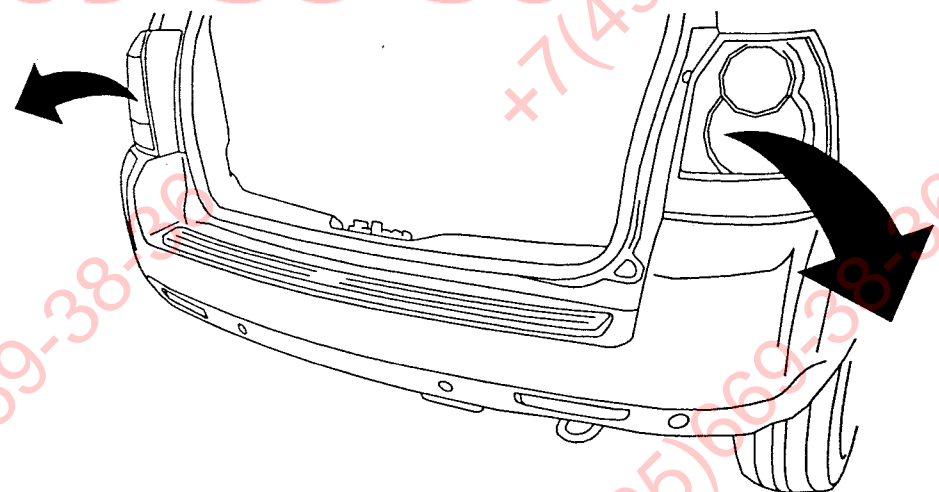

02

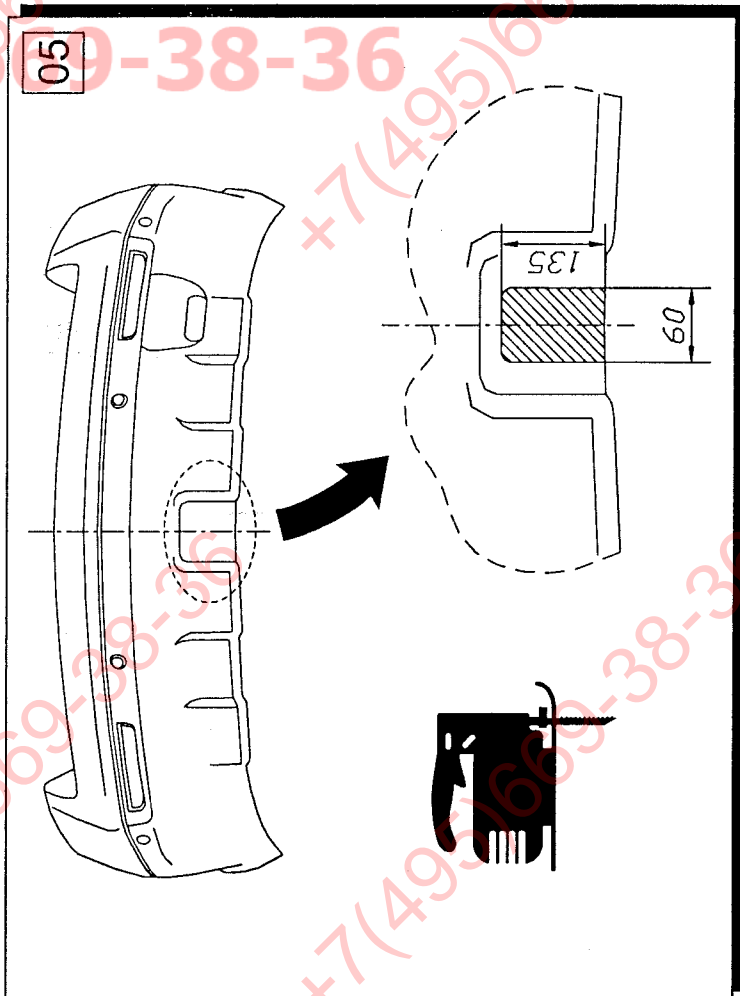
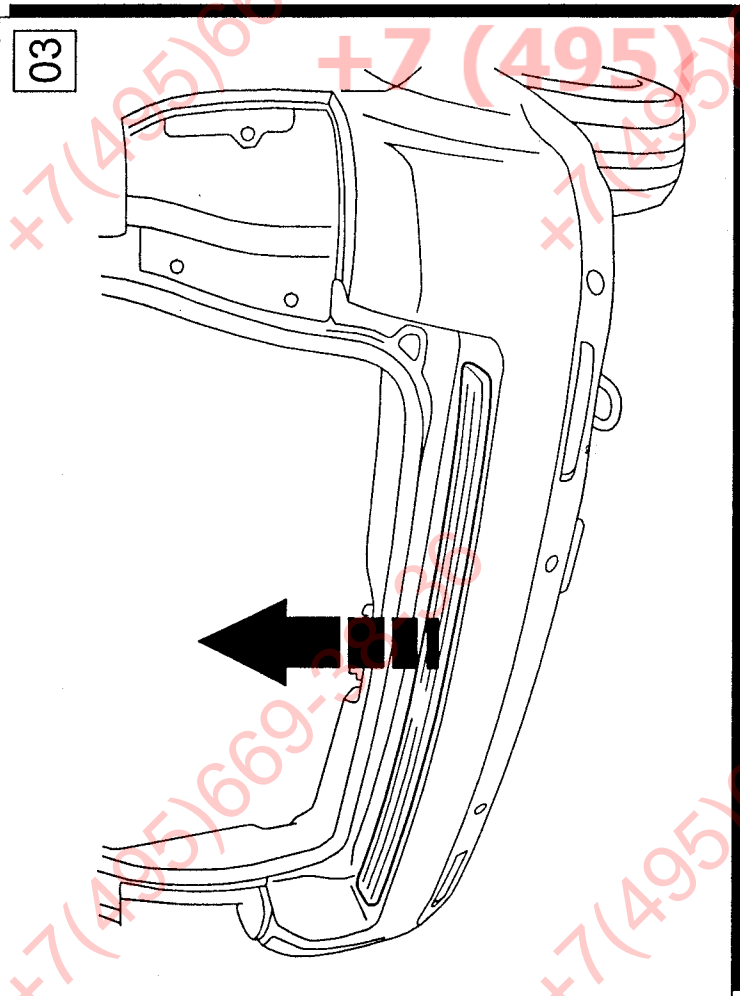
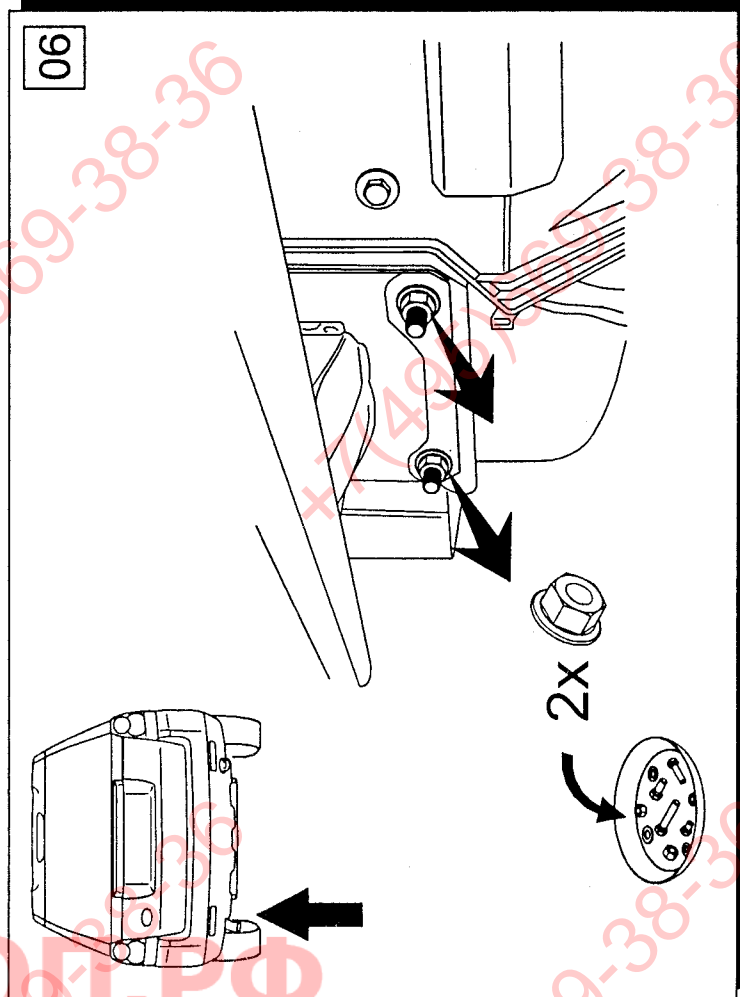
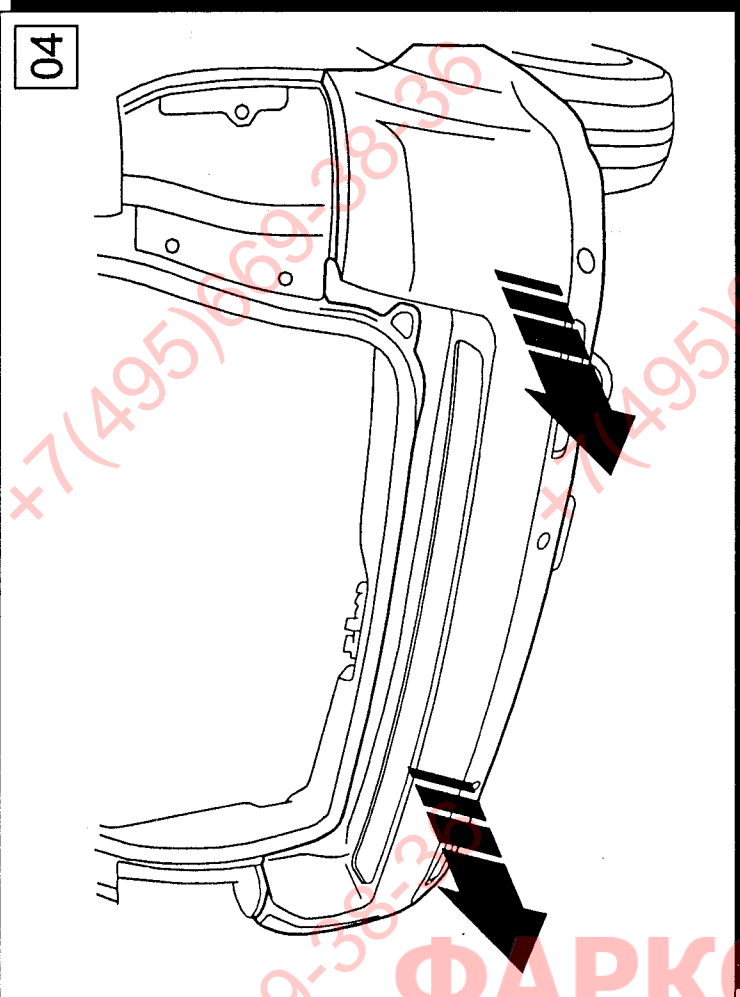

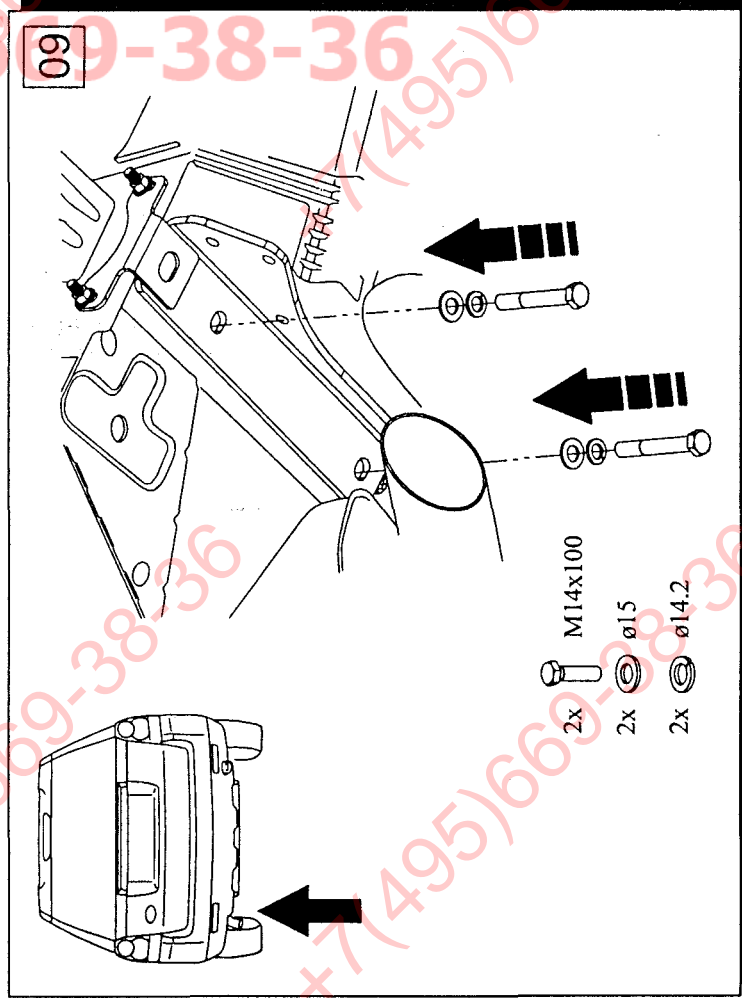
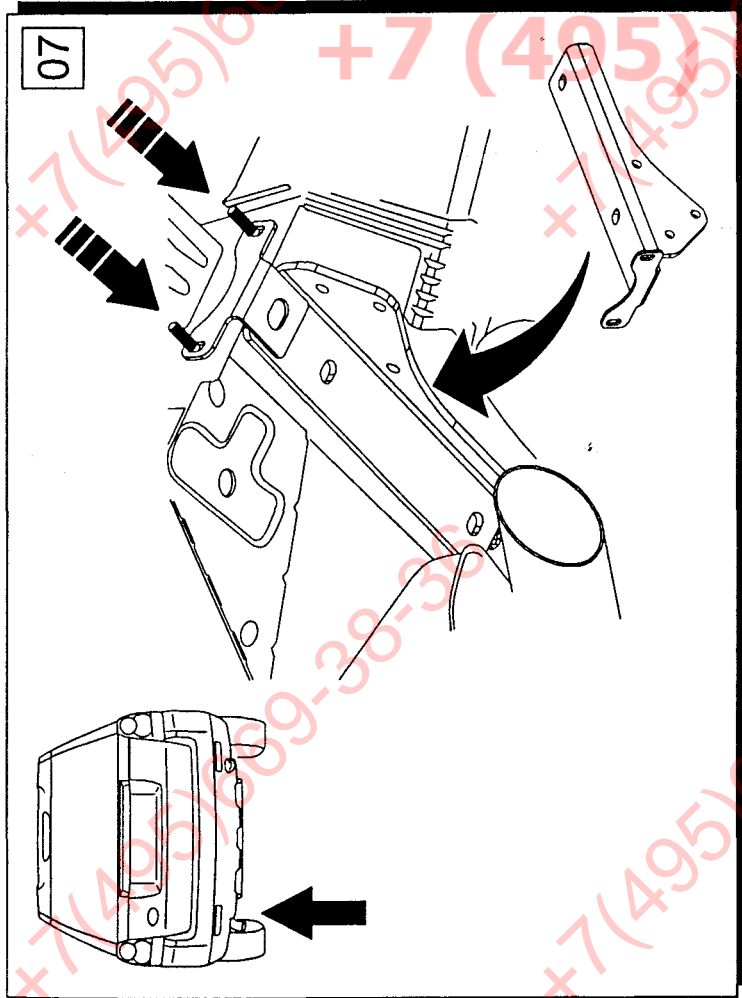
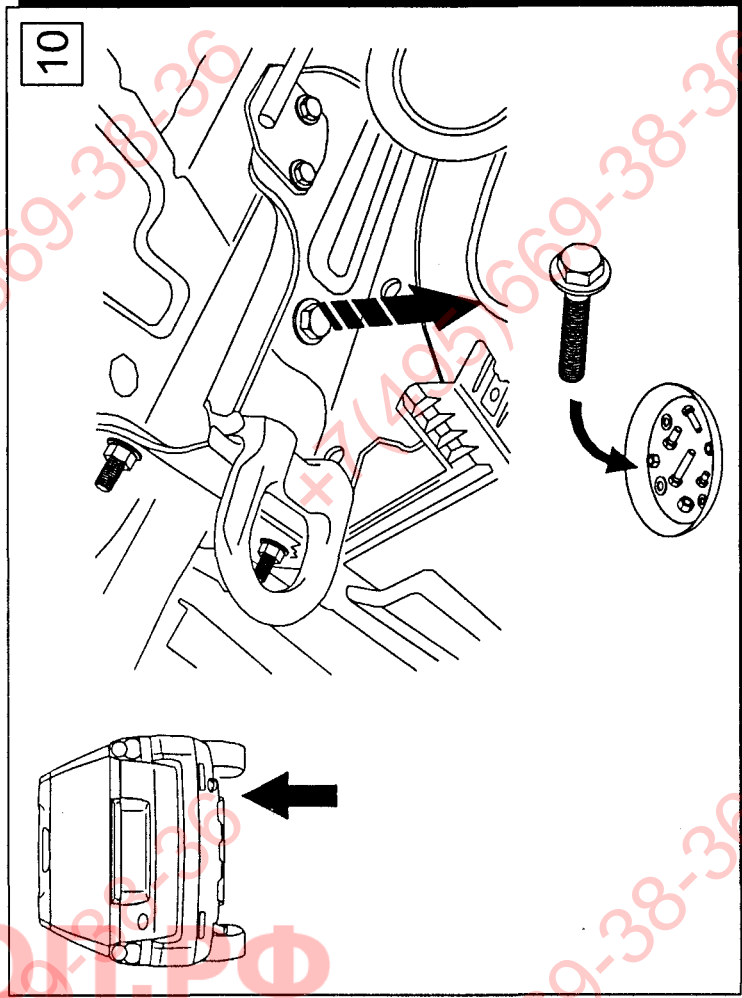
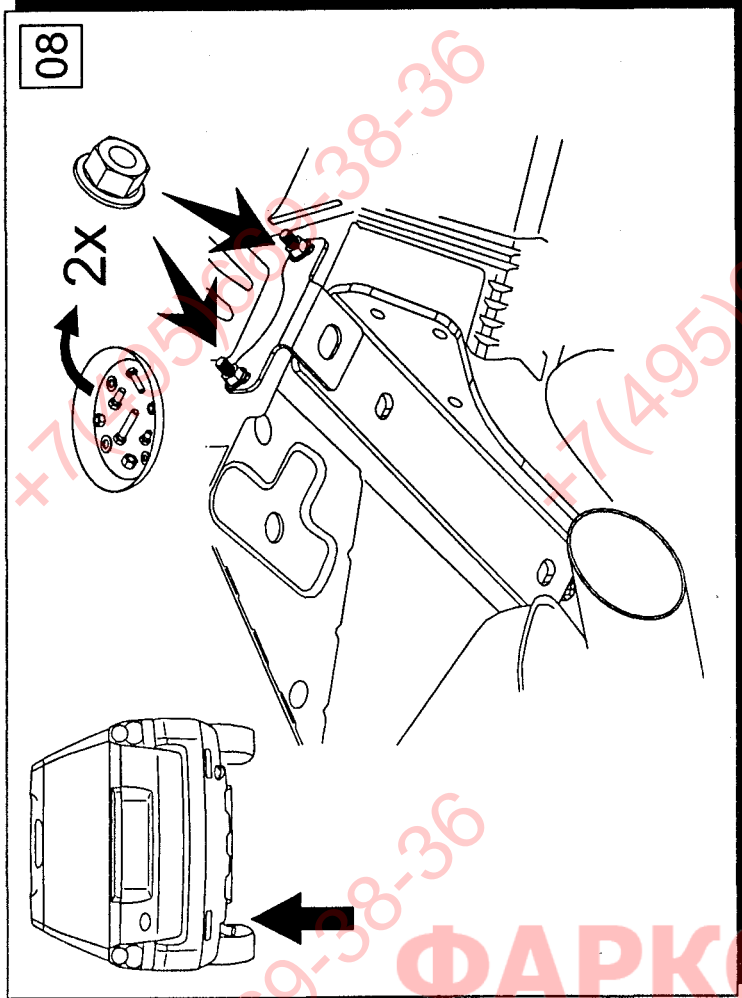

12

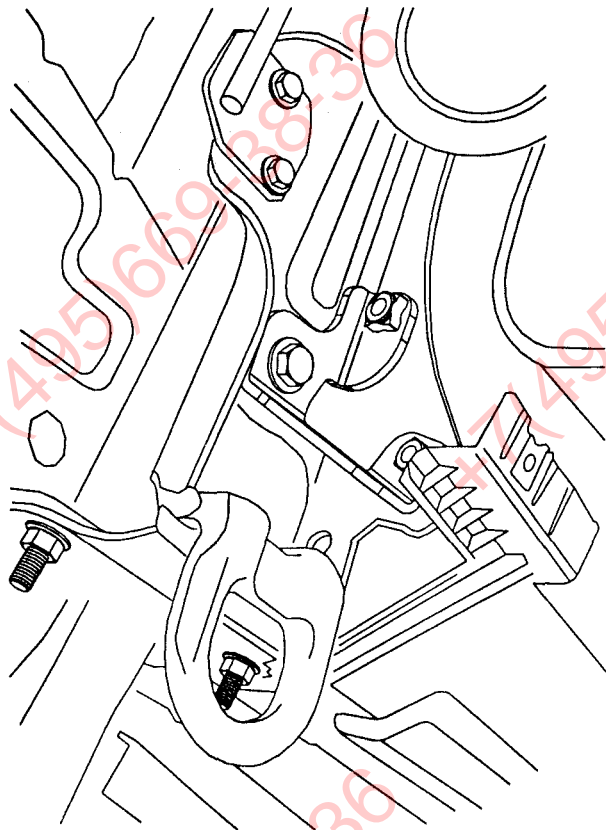

14

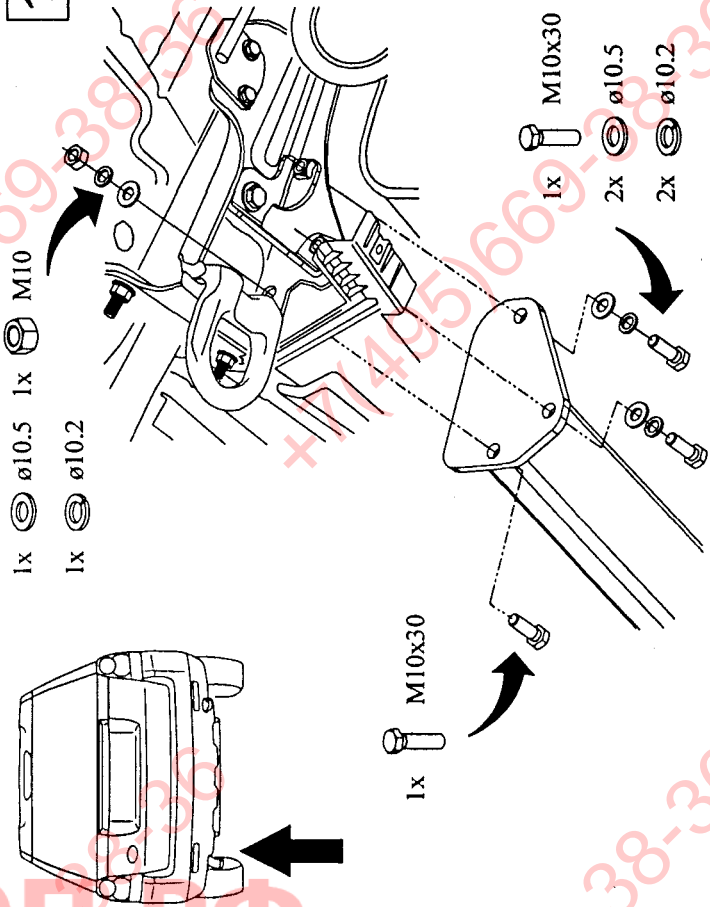

11

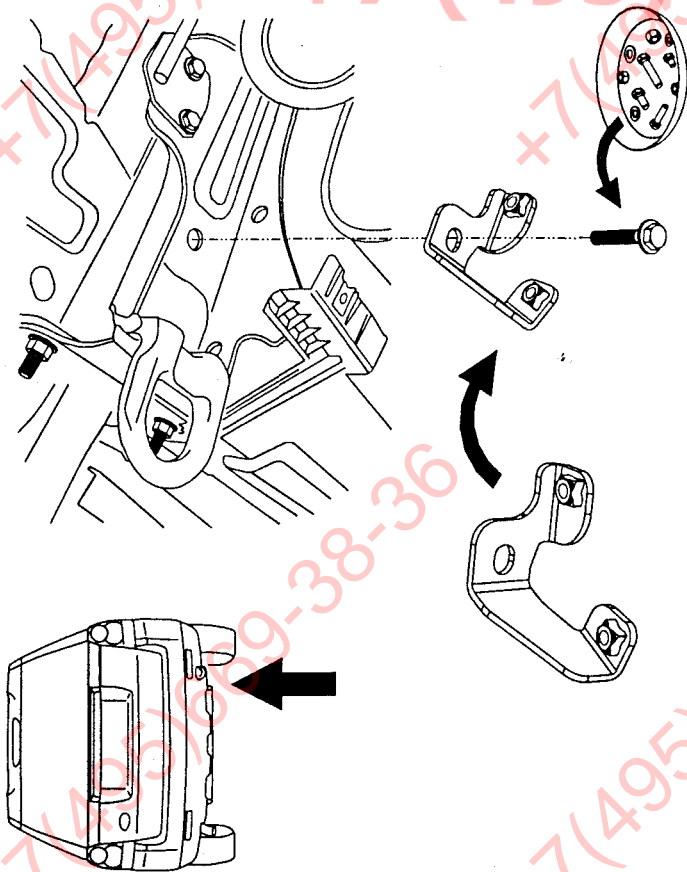

13

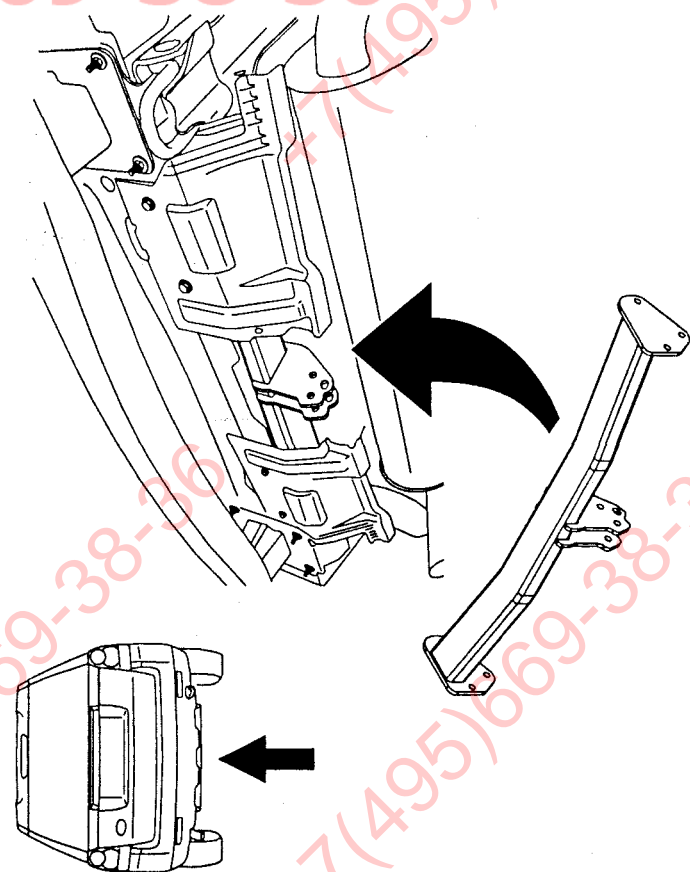

16

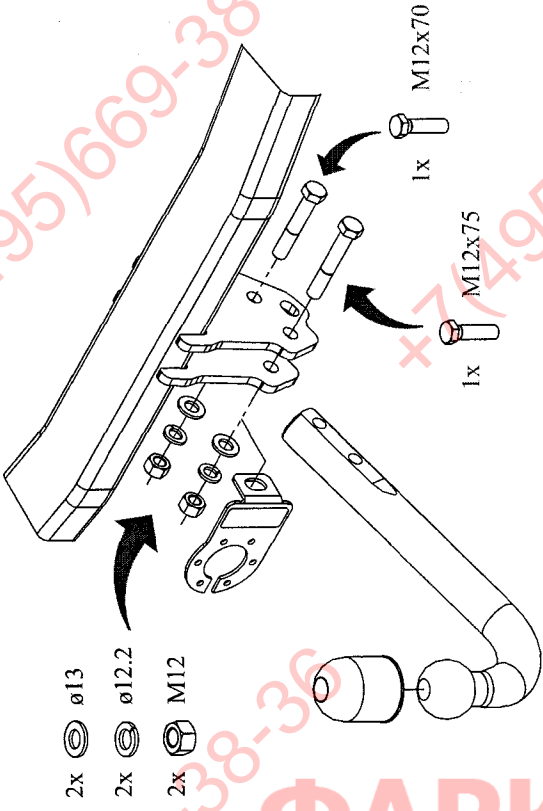

18

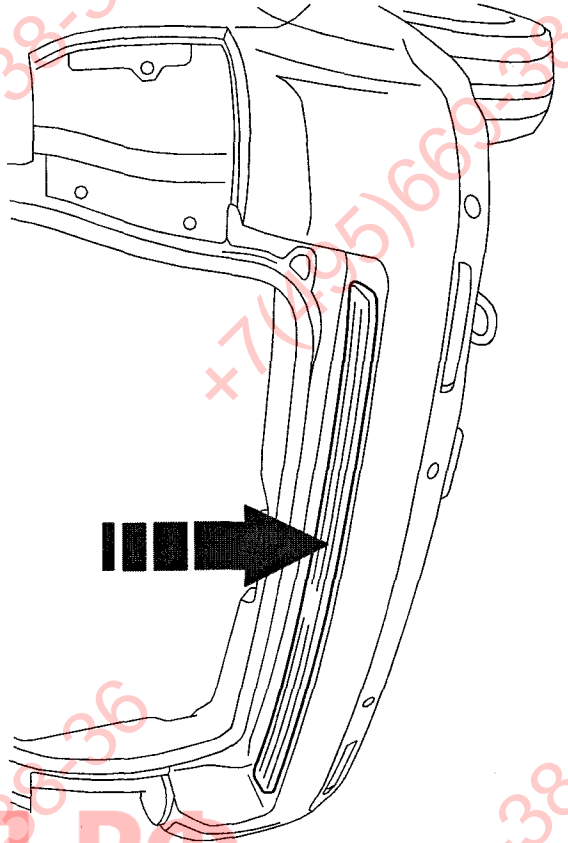

15

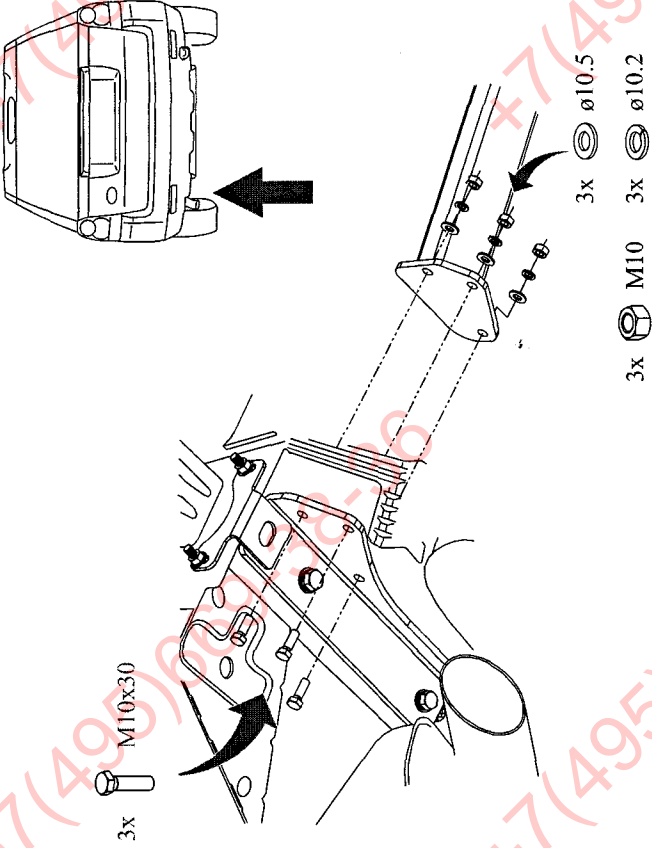

17

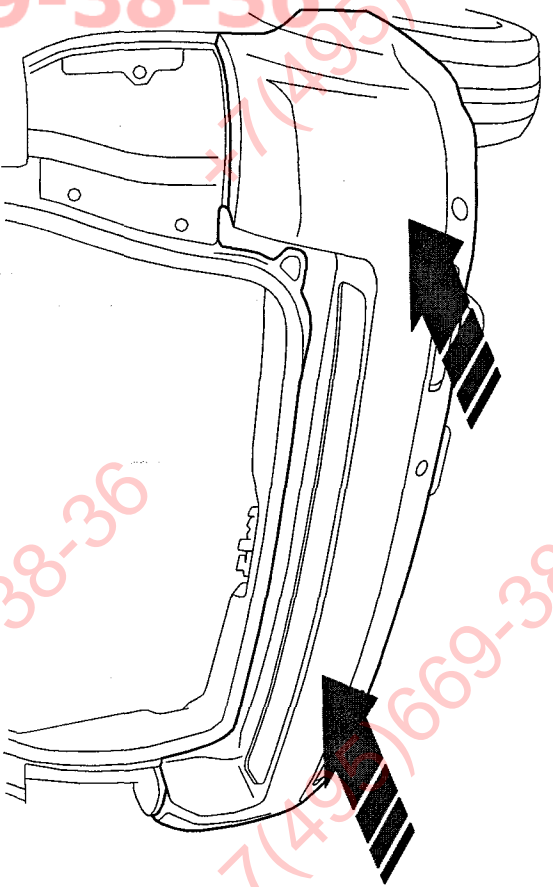

20

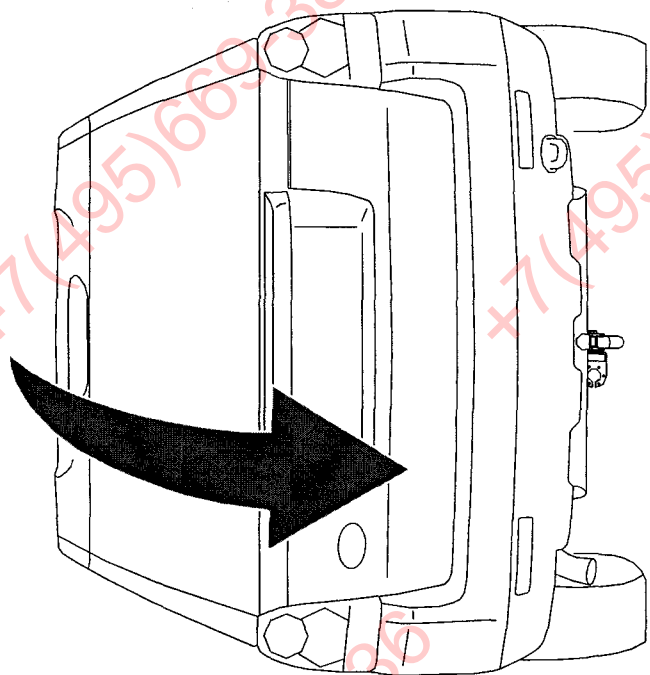

19

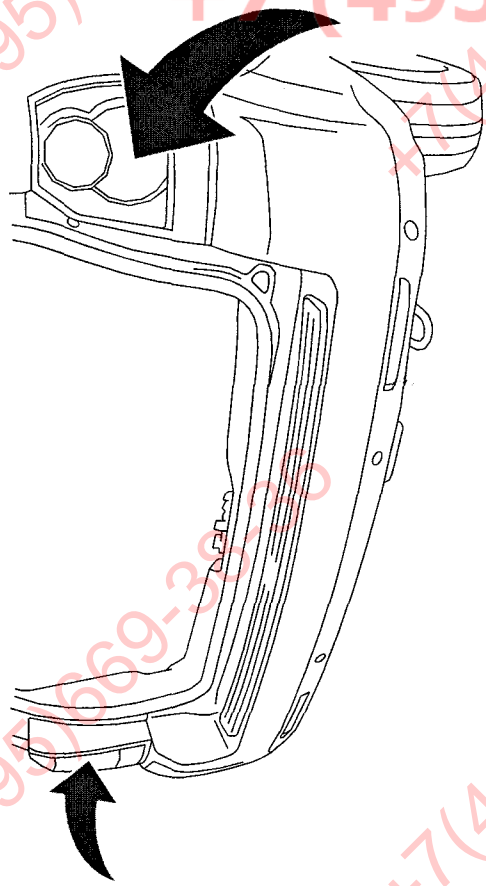

ФАРКОП.РФ